

# MGD – Murco Gas Detector

## Check / Calibration Procedure\*



Content Page	
1- Introduction	2
2- Electrical Set-Up	2
3- Bump Test	2
4- Calibration	3
4.1 Exchange Sensor board	3
4.2 Gas Calibration	3
5- Additional recommendations	5
a. False Alarms	5
b. Double check connections are correct	5
6- Sample Test Certificate for System Log	6

### \*Technician use only

*These units must be checked /tested and /or calibrated by a suitably qualified technician who must test or calibrate the unit in accordance with the instructions as provided or set out in the relevant manual and the standards set down in their particular industry/country. Suitably qualified operators of the unit should be aware of the regulations and standards set down by their industry/country for the testing or calibration of this unit. These notes are only intended as a guide and insofar as permitted by law the manufacturer accepts no responsibility for the Calibration and Testing or operation of this unit.*

*Failure to test or calibrate the unit in accordance with the then applicable instructions and with industry guidelines may result in serious injury including death and the manufacturer is not liable for any loss injury or damage arising from improper testing or calibration or inappropriate use of the unit.*

*The testing or calibration of the unit must be carried out by a suitably qualified technician, in accordance with the testing or calibration manual and in compliance with locally applicable guidelines and regulations.*

10 ASH (1)

Murco Ltd.  
114a Georges Street Lower, Dun Laoghaire Co Dublin. Ireland,  
e-mail: info@murco.ie web: www.murcogasdetection.com



## INTRODUCTION

The frequency and nature of testing or calibration may be determined by local regulation or standards. EN378 and the FGAS Regulation require an annual check in accordance with the manufacturer's recommendation.

**For 1 level models, Murco recommends an annual check consisting of resetting units electrically to the factory calibration settings and then carrying out a bump test. A gas calibration should be carried out every three years.**

**For 2 level systems, Murco recommends annual checks by resetting units electrically to the factory calibration settings and a bump test and replacement of the sensors with a Murco pre-calibrated certified sensor every three years. The alternative to replacement is an on-site gas calibration. Sensor replacement may be more cost effective, eliminate end of life concerns, and constantly renew the detection system.**

**If the sensor is exposed to a large leak it should be tested to ensure correct functionality by electrically resetting to the factory calibration settings and carrying out a bump test.**

There are two concepts that need to be differentiated: bump test and calibration

**Bump Test:** This consists of exposing the sensor to a gas. The objective is to establish if the sensor is reacting to the gas and all the sensor outputs are working correctly. A quantified bump test is one where gas of a known concentration is used.

**Calibration:** This consists of exposing the sensor to a calibration gas setting the "Sensor Standby voltage", the alarm set points "Alarm Threshold Voltages", and checking/adjusting all the outputs, so that they are activated at the specified alarm gas concentrations when exposed to this gas.

It is required by EN378 to record the check results in the Logbook.

Before you carry out the bump test or calibration:

- 1- Advise occupants, plant operators, and supervisors.
- 2- Check if the MGD is connected to external systems such as sprinkler systems, plant shut down, external sirens and beacons, ventilation, etc. and **disconnect as instructed by the customer.**
- 3- For 1 level systems you must deactivate the 3-min alarm delay if selected by moving jumper JP1 to "off" position. For 2 Level systems upon power up there is a delay of 3 minutes before the Green power LED turns on.
- 4- For Bump Test or Calibration, MGDs should be powered up overnight.
- 5- If a unit has been powered off for a short time, say due to maintenance, it will normalise within a few minutes. If sensors have been in long-term storage or the detectors have been turned off for a long period, normalisation would be much slower. However within 1-2 hours sensors should have dropped below the low alarm level and be operational. You can monitor normalisation progress exactly by monitoring the sensor output, see Table 1, page 5.



## 2. Electrical reset / bump test (every year)

Electrical reset is based on the calibration information found on the label on the side of the enclosure and is unique to that sensor.

Tools required:

- 1- A voltmeter– crocodile clips recommended
- 2- Murco's factory set point electric values as shown on the rating label
- 3- Estimate 10 min per sensor

### 2.1 Electrical Reset of 1 level system:

Reset, if necessary, the Standby and Alarm Threshold Voltage to the factory settings as shown on the calibration label.

First disable the 3-minute alarm delay on a one level system by moving the jumper link at **JP 1 to the "OFF" position**, diagram 1.

Two adjustments are required and they are all performed on the controller unit.

For Sensor Standby Voltage, connect your DC voltmeter between 4(0V) and 2(+V) on CN1, CN2, etc as shown in Diagram 1 and adjusting pot P1 for channel 1, P2 for channel 2, etc.

For Alarm Threshold Voltage, connect your DC voltmeter between 4(0V) and 1(+V) on cal header as shown in Diagram 1 and adjusting pot P3 for 1/2 channel units and P7 for 4/6 channel units.

For IR 1 level units, carry out the adjustments on the controller as before. For the sensor standby voltage connect the voltmeter between 4 (0V) and 2 (+V) on CN1, CN2, etc as shown in Diagram 1 and adjusting Pot P1 for channel 1, P2 for channel 2, etc and using the value of 2.0V.

For alarm threshold voltage. Connect the voltmeter between 4(0V) and 1(+V) on the cal header as shown in Diagram 1 and adjust P3 on a 1/2 channel unit and P7 on a 4/6 channel unit to 3.5V.

There is one other adjustment on the sensor board. Connect the DC voltmeter between 0V and High as shown in Diagram 3 and adjust P7 to the alarm set point as per the rating label (normally 1.2V).

Carry out a bump test to ensure the sensor is functioning correctly. If the sensor does not go into alarm carry out a gas calibration.

If the factory set point information is not on the calibration label (as with older units) check the serial number of your gas detector on the rating label and sensor PCB and contact Murco for the appropriate set point values.

Finally return the jumper **JP1 to the original position.**

## 2.2 Electrical Reset of 2 level system

Reset, if necessary, the Standby and low /high Alarm Threshold Voltages to the factory settings as shown on the calibration label. This is performed on the sensor PCB.

For Standby voltage, connect your DC voltmeter between TP5 (0V) and TP4 (+V) as shown in Diagram 2 and adjusting pot RV1.

For low-level alarm voltage, connect your DC voltmeter between TP5 (0V) and TP2 (+V) as shown in Diagram 2 and adjusting pot P8.

For high-level alarm voltage, connect your DC voltmeter between TP5 (0V) and TP1 (+V) as shown in Diagram 2 and adjusting pot P7.

For 2 level IR units, there are 2 adjustments for the alarm levels and the standby voltage is fixed. The values for the electrical calibrations are on the rating plate. To adjust the low level alarm monitor between 0V and LOW as shown in Diagram 3 and adjust P8 to the required voltage. For the high level alarm monitor between 0V and HIGH as shown in Diagram 3 and adjust P7 to the required voltage.

If the factory set point information is not on the calibration label (as with older units) check the serial number of your gas detector on the rating label and sensor PCB and contact Murco for the appropriate set point values.

## 3 BUMP TEST

Ideally bump tests are conducted on site in a clean air atmosphere.



**3.1 Semiconductor and IR sensors for hydrocarbons:** We offer cylinders of calibration gas at known concentration and ampoules for ammonia (NH<sub>3</sub>) at 100ppm and 1.000 ppm and using these constitute a quantified bump test.

If Calibration Gas is not available you can carry out a non-quantified bump test using a gas cigarette lighter. By cracking the valve open without igniting the gas, you release the gas onto the sensor and force it into alarm. Check that alarm lights and relays are activated

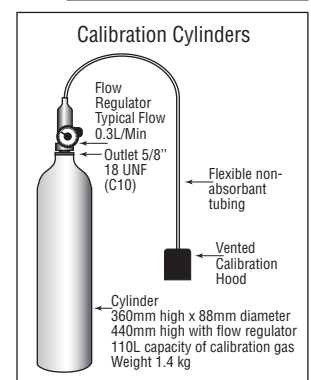



**3.2 Infrared sensors for CO2 Detection:** For a quantified bump test you can check the infrared sensors for carbon dioxide using Murco ampoules filled with CO2 at 5000ppm or calibration cylinders.

If these are not available, you can carry out a non-quantified bump test by breathing on the sensor. The human breath has enough CO2 to trigger the alarm.

If the bump test is not successful then carry out a gas calibration, see below.

**3.3 Bump test using gas ampoules:**

- 1- Make sure that both the ampoules and the calibration beaker are clean and dry.
- 2- Unscrew the beaker hold screw and place the ampoule so that it sits in the base of the beaker. As per illustration.
- 3- Tighten on the screw ampoule without breaking it.
- 4- Remove the enclosure lid of the gas sensor (not in Ex area and in one level units as monitoring of voltage can be done on controller).
- 5- Connect volt meter for 1 level unit. On the channel undertest between Pin 4 and Pin2 and for 2 level semiconductor between TP5 and TP4. For IR boards between OV and VS to monitor sensor response
- 6- Place the beaker over the sensor head (using an adaptor if required) or, if an Exd or Remote sensor head version, M35 or M42 thread, screw the beaker on the remote sensor head. It should be as tight a fitting as possible to allow maximum exposure to the gas.
- 7- Tighten on the ampoule until it shatters allowing the content to diffuse in the beaker. It should be left in place for approximately 5 min.
- 8- Voltage output will increase. This confirms that the sensor is responding. In the case of ampoules a response equivalent to 50% or greater of the ampoule concentration will be satisfactory.
- 9- Carefully remove any ampoule remains from the gas detector.

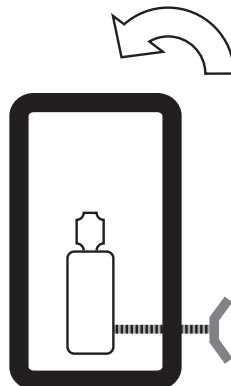

**3.4 Bump Test Using Gas Cylinders.**

Remove the enclosure lid of the gas sensor (not in an Ex area) and controller (non applicable to Exd Remote sensor and vent pipe model, 1L units as monitoring of voltage can be done on controller).

Connect the voltmeter for 1 level unit. On the channel undertest between Pin 4 and Pin2 and for 2 level semiconductor between TP5 and TP4. For IR boards between OV and VS to monitor sensor response.

Expose the sensor to gas from the cylinder. You can place the entire sensor into a plastic bag or use a plastic hose/hood to direct gas to the sensor head.

**4 CALIBRATION (every three years)**

The alternatives we describe are:

- 4.1 Exchanging the sensor board – available for 2 level units and 1+2 level IR units.
- 4.2 Gas Calibration

**4.1 EXCHANGE SENSOR BOARD – available for 2 alarm level system and 1+2 level IR units (every 3 years)**

Murco recommends exchanging your sensor PCB for a newly pre-calibrated certified Murco unit every 3 years.

Tools required:

- 1- A pre-calibrated sensor board
- 2- A voltmeter – crocodile clips recommended
- 3- Estimate 10 min per sensor

In this case you need to:

- 1- Power off the unit and remove lid of sensor enclosure.
- 2- Note the colour code of the cable in positions 1,2,3,and 4 of the connector block.
- 3- Undo the cable and 2 screws securing sensor board and remove.
- 4- Fit the new pre-calibrated sensor and reconnect the cable in the correct colour sequence at positions 1,2,3 and 4.
- 5- Power on the unit and allow to stabilise for 15 min.
- 6- Check voltage readings on positions 1,2,3, and 4 as per procedure in Table 1, page 5, to ensure that wiring is correct. Note also in the table how to monitor the sensor as it normalises.
- 7- Carry out a bump test to confirm the sensor is responding.
- 8- Keep records of the test date, sensor serial number, and any observation.

There are a number of advantages to sensor exchange. It is simpler and quicker than gas calibration. Murco guarantees the correct calibration and functioning of the new sensor, which is supplied with a calibration certificate and finally, you won't face any problems of sensor deterioration or end-of-life.

**4.2 GAS CALIBRATION**

This is the adjustment of the gas detector using calibration gas.

Murco offers a calibration kit that consists of a Calibration gas cylinder and a flow regulation valve with flexible non-absorbant tubing and vented calibration hood.

In some cases this option may be expensive relative to sensor exchange because of the cost of visiting a site, calibration gas and valve, and a surcharge on the freight cost of the calibration gas as it is classified as a hazardous substance (ampoules are not classed as hazardous). The procedure involves electrical set-up followed by adjustment using calibration gases.

Equipment required:

- 1- Gas cylinders with the appropriate calibration gas concentrations
- 2- Gas canister with zero air to calibrate /check the Sensor Standby Voltage, required if the sensor environment is not clean.
- 3- Flow gas valve – rate 0.3L/min
- 4- A voltmeter
- 5- Estimate 30 min per sensor

The procedure differs slightly depending on the number of alarm levels.

**4.2.1 Gas Calibration ONE LEVEL of ALARM UNITS**

First disable the 3-minute alarm delay on a one level system by moving the jumper link at **JP1, diagram 1** to the off position. Two adjustments are required and they are all performed on the controller unit.

a. **Sensor Standby Voltage (SSV)**

This is the standby output for the sensor in clean air. When gas is present around the sensor, this voltage will increase.

IF **SSV** is greater than **the alarm threshold voltage**, as in when a gas leak occurs, then an **alarm condition** occurs - red LED, siren, relay operates. (When JP1 is in "on" positions there is a 3 minute delay)

IF **SSV falls below 0.18 V**, a **fault condition** will be shown on the controller - red LED, no siren, relay does not operate.

Connect a Voltmeter between Pins 4 (-Ve) & 2 (+Ve) of sensor terminal connector block for each channel in turn (CN1, CN2 Etc.) and adjust calibration pot (P1, P2 Etc.) to the SSV value as per calibration label on side of enclosure for IR set SSV to 2V.

This value should be already set unless age or background has caused drift.

b. **Alarm Threshold Voltage (ATV)**

ATV is the voltage at which the alarm and relay activate at a given gas concentration. This voltage is normally set 3.5V.

Connect a Voltmeter (0-10 volt scale) across pins 4 & 1 of the header marked "CAL" on the controller board.

This voltage (3.5V normal factory setting) is set using:

- 1 or 2 channel system controllers - the threshold pot "P3"
- 4 or 6 channel system controllers - the threshold pot "P7"

Connect a Voltmeter between Pins 4 (-Ve) & 2 (+Ve) of the sensor terminal connector block for each channel in turn (CN1, CN2 Etc.) Apply calibration gas of the desired concentration e.g. 1000 ppm in air to the sensor and wait until the sensor output signal stabilises, then adjust the pot that corresponds to the channel being calibrated, i.e. P1 for channel 1, P2 for channel 2, etc. This should be adjusted until the sensor goes into alarm – the red LED turns on (a voltage of approximately 3.55V). Remove the calibration gas and allow the sensor to return to its standby voltage. Record this voltage reading and keep on record for subsequent electrical set-ups. This is now calibrated for the gas concentration used. Repeat for any subsequent channels. Finally return jumper JP1 to its pre-calibrated position.

For IR connect voltmeter between 0V and VS on the sensor board as per Diagram 3. Apply calibration gas of the desired concentration eg. 5000 ppm in air to the sensor and allow the sensor output to stabilize and record this voltage. Connect voltmeter between 0V and high and adjust P7 to 50mv below the recorded voltage. The sensor will be in alarm.

Connect the voltmeter between pins 4(-Ve) and 2(+Ve) of the channel being calibrated. The pot on the controller for the corresponding

channel being calibrated should be adjusted i.e. P1 for channel 1, P2 for channel 2, etc. This should be adjusted until the sensor goes into alarm - the red LED turns on (a voltage of approximately 3.55V). Remove the calibration gas and allow the sensor to return to its standby voltage. Keep the recorded voltage on record for subsequent electrical set-ups. This is now calibrated for the gas concentration used. Repeat for any subsequent channels. Finally return jumper JP1 to its pre calibrated position.

**4.2.2 Gas Calibration TWO ALARM LEVELS UNITS**

The delay on a 2L system is approximately 25 seconds and cannot be deactivated. All adjustments are performed on the sensor PCB and there are three elements to be adjusted: the Standby Voltage and two Alarm Thresholds.

a. **Sensor Standby Voltage (SSV)**

The factory settings are shown on the calibration label on the side of the enclosure.

Connect the voltmeter between TP5 (0V) & TP4 (+Ve) and adjust pot RV1 for 0.3V (on IR units SSV is fixed).

This value should be already set correctly unless age or background has caused drift.

b. **Alarm Threshold Voltage (ATV)**

*Low Threshold:*

Connect voltmeter between TP5 (0V) & TP2 (+Ve)/0V and low for IR units, set the voltage as shown on the calibration label by adjusting pot "P8".

*High Threshold:*

Connect voltmeter between TP5 (0V) & TP1 (+Ve)/0V and high for IR units, set the voltage as shown on the calibration label by adjusting pot "P7".

**Remember there is an inbuilt delay response to an alarm of approx. 25 sec on both alarm levels.**

Monitor voltage between TP5 (0V) & TP4 (+Ve)/0V and VS on IR units. Apply the low concentration calibration gas to the sensor and wait until the sensor output signal stabilises. Record this voltage. Apply the high concentration calibration gas to the sensor and wait until the sensor output signal stabilises. Record this voltage.

If the voltages recorded for the low and high alarms differ from the factory settings shown on the calibration label then adjust P8 and P7 as above to the new values. Record and use these new values for subsequent electrical set-ups.

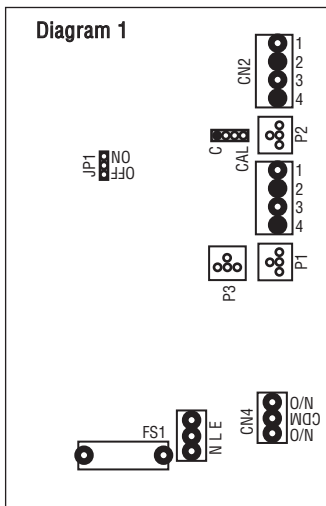

MGD 1 or 2 channel unit.

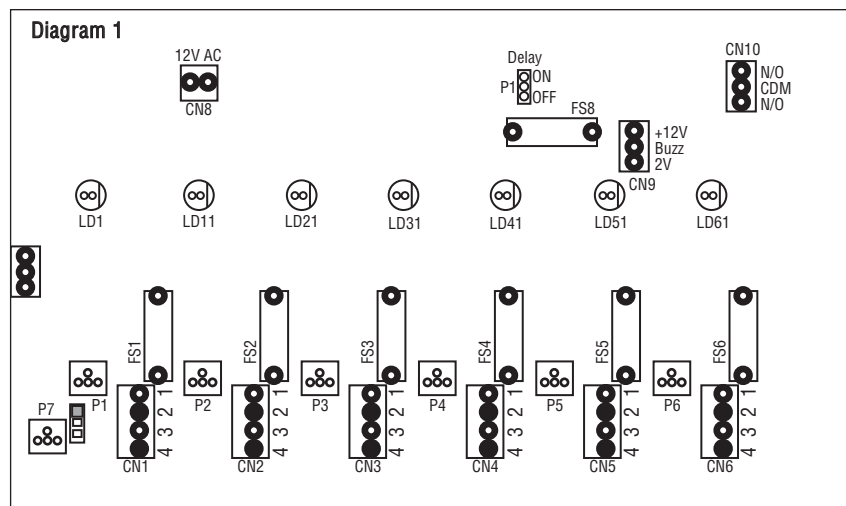

MGD 4 or 6 channel unit.

**Diagram 2: Two Level Sensor**

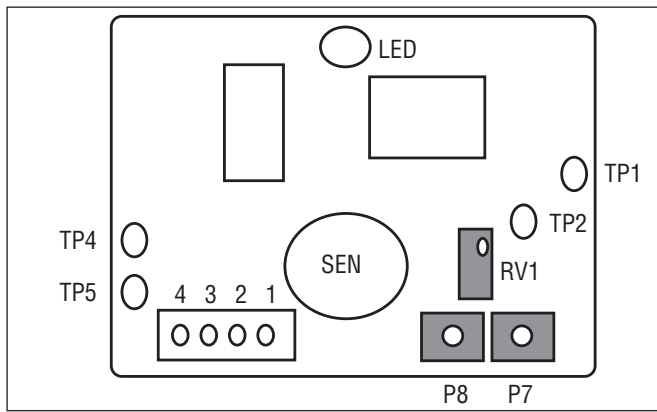

**Diagram 3:**

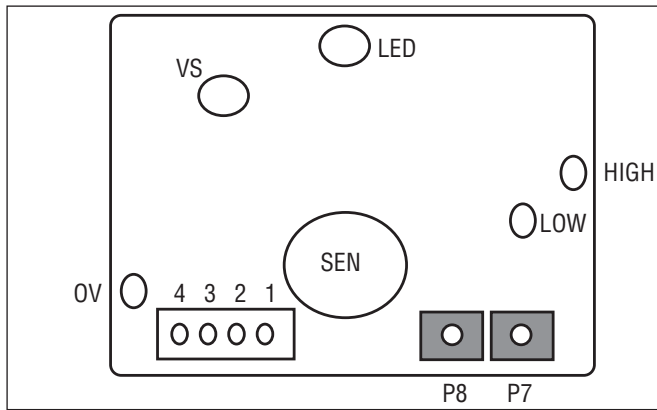

The High threshold voltage must be set higher than the low threshold, or the unit will not function correctly.

**5- ADDITIONAL RECOMMENDATIONS**

**5.1 FALSE ALARMS:** If false alarms are being triggered by background gases, paint fumes, etc, or extreme humidity or temperature conditions, you may adjust the settings to compensate.

**Table 1. Connections correct values**

Position Number	At the Sensor	Controller	Without Sensor Fitted
4	Is the negative side of the power supply	Negative	Negative
1	Power Supply 7.2V minimum reading, unless you have power drop reduction.	+10V	+12-15V
3	Approximately 4-5V	+4.8-5V	+5V
2	One level system - sensor standby voltage* as shown on the calibration label on the side of the enclosure. Two level system - typical Internal reference values, approximately	(0=Fault) +0.4V +1.6V +2.8V	0 Sensor in standby Low Alarm Condition High Alarm Condition

\* The voltage signal from the sensor will on power up start high and gradually fall (in clean air) to the SSV value shown on the calibration label. IR unit will display 0Volts until the 2 minute warm-up has finished.

You can monitor this as follows:

1 level systems: Connect a Voltmeter and monitor voltage between Pins 4 (-Ve) & 2 (+Ve) of the sensor terminal connector block for each channel in turn (CN1, CN2 Etc.) For IR monitor between OV and VS.

2 level systems: Connect voltmeter and monitor voltage between TP5 (0V) & TP4 (+Ve). For IR monitor between OV and VS.

**One Level Systems**

You should reduce the SSV level in 0.5V increments until the condition clears.

**Two Level Systems**

You should adjust the relevant alarm threshold upwards in 0.2Volt increments until the condition clears.

**5.2 DOUBLE CHECK CONNECTIONS ARE CORRECT:**

To make sure the gas detectors are wired up correctly you can check the voltages at the sensor cable terminal blocks on the controller PCB or sensor PCB using a 0-10V voltmeter as outlined below in Table 1.

Place the negative probe on terminal position 4 and with the positive on 1, 3, 2, check the Volts values. The readings are lower at the sensor due to power drop in the line.

The terminals should have the under listed values:

